

Resilient PV Retrofit and Storage Ready Guidelines

Introduction

The NYSolar Smart Distributed Generation (DG) Hub is a comprehensive effort to develop a strategic pathway to a more resilient distributed energy system in New York that is supported by the U.S. Department of Energy and the State of New York. This DG Hub fact sheet provides information to installers, utilities, policy makers, and consumers on how to add an energy storage system (ESS) to existing solar PV systems to create resilient PV or make new PV systems “storage ready”. For information on other aspects of the resilient PV market, please see the companion fact sheets on resilient solar economics, policy, and hardware and a glossary of terms at: www.cuny.edu/DGHub.

Background

The majority of residential and commercial solar PV systems in the U.S. today are designed to provide energy to the building or site on which they are located, and operate in parallel with the electric utility. These systems are referred to as “grid connected” systems. When the electrical grid goes down during an outage, the inverters have “anti-islanding” protections as defined by electrical codes and standards (UL1741¹/IEEE1547) that de-energize the systems to ensure the safety of grid utility workers. This results in a system that cannot be utilized in a grid outage, which often times is the most critical time to have power. With appropriate switches, controls, and planning, systems can be made to operate in both grid-connected mode as well as off-grid. Adding an ESS is the most common way to retrofit an existing PV system to enable off-grid power.

This fact sheet will cover two related topics:

1. Retrofitting existing solar with an ESS, and
2. Considerations for making new solar installations “storage-ready.”

The components required, electrical system layout options, added or avoided costs, financing and warranty considerations, as well as other items for consideration will be outlined in this fact sheet. For the purposes of this paper, it is assumed that the existing system is a standard grid-connected PV system with a grid tied inverter² as shown in the following figure.

CONTENTS

1. Introduction
2. Background
3. Design Considerations
4. Equipment List
5. Sizing for Storage
6. Site Considerations
7. Financing Considerations
8. Investment Tax Credit
9. Warranty
10. Interconnection and Net Metering
11. Costs
12. Storage-ready guidelines
13. Appendix: Work specification language

¹ http://ulstandards.ul.com/standard/?id=1741_2

² For a description of inverter types, see the “Inverters” section of the DG Hub’s [Resilient PV Hardware Fact Sheet](#).



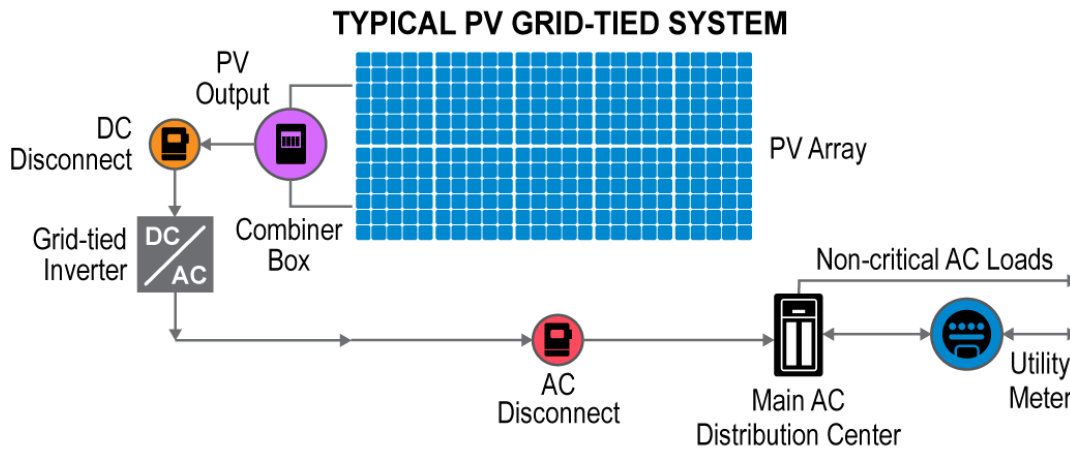

Figure 1: Typical Grid Tied PV System

Design Considerations

Usage Intent

The usage of a solar and ESS will influence design considerations. Examples of system uses include:

Emergency power: Systems intended to provide back-up power should have an inverter that can operate in backup mode, and the appropriate electrical infrastructure to isolate the system from the grid. Batteries should have low parasitic losses; deep cycle batteries are not necessary as the system will be used infrequently.

Demand management: Systems intended to shave or shift peak demand should select batteries that are deep cycle, and utility communication may be necessary. Battery banks must have sufficient capacity to discharge for the duration of the facility peak in order to achieve benefit.

Grid services: Systems intended to provide ancillary services like frequency and voltage regulation should select batteries capable of quick response and include control software capable of communicating with the organization to which services are being provided. Currently, utilities in New York State do not offer compensation for grid services. All ancillary services are managed by NYISO, which are periodically made available through a request for proposal/qualifications.³ While more attention to system integration with automated communication systems is required, it is possible to accept system commands through automated signals. This functionality is not currently being leveraged to the largest extent possible in New York State, but capabilities are in development. Industry organizations are developing standards such as MultiSpeak⁴ and Open ADR⁵ that should allow for additional compatibility. For ancillary services, systems may be subject to minimum size requirements to provide services to NYISO. See the DG Hub [Economics and Finance of Solar+Storage](#) fact sheet appendix of available program for solar+storage for more information.

³ Information Related to ISO Markets and Services -

http://www.nyiso.com/public/media_room/recent_postings/index.jsp

Ancillary Services Training -

http://www.nyiso.com/public/webdocs/markets_operations/services/market_training/workshops_courses/Training_Course_Materials/Market_Overview_MT_101/Ancillary%20Services.pdf

⁴ <http://www.multispeak.org/>

⁵ <http://www.openadr.org/>



Combined uses: Systems intended for multiple uses will need control systems that can deliver all of the desired functionality and logic to make decisions on hierarchy. The systems may require automatic switching, and may consider using multiple chemistries (for example, lead acid for emergency power and li-ion for grid services).

RESILIENT PV ORDER OF OPERATIONS

To better understand how system components work together, the order of operations below describes how resilient PV equipment might function during the different modes of operation:

1. System is operating in grid-connected mode, the batteries idle at a constant state of charge, and the PV system is producing power based on the solar energy available. All loads are connected. If there is excess energy produced, it is pushed back on to the grid.
2. During grid-connected mode, the system can provide grid services based on signals from the utility, and can perform demand management based on peak billing windows, and usage information from previous days.
3. The grid drops, and the power goes off. The transfer switch is automatically (or manually) flipped from grid to backup mode. The dual function inverter switches from “grid mode” to “emergency mode”.
4. The dual function inverter provides stored energy from the battery to the backup AC loads (i.e. critical loads). The PV array charges the battery bank. If there is excess energy produced and the battery bank is fully charged, the power point tracker within the inverter throttles back the production.
5. If the battery voltage drops below the required voltage, the dual function inverter sends a signal to the backup generator (optional) to turn on to supply the load and charge the battery bank.
6. Once the batteries are full, the generator shuts off.
7. When grid power is restored, the transfer switch is automatically (or manually) flipped from backup to grid. The dual function inverter then switches from “emergency mode” back to “grid mode”.

System Configuration

System configuration is described in terms of how the ESS is integrated into the PV system. An ESS can be integrated into the system on either the DC (DC-coupling) or AC (AC-coupling) side of the system. A DC-coupled configuration is often preferable for new resilient PV systems, while an AC configuration is common when adding storage to an existing PV system.

DC Coupled Systems

A DC Coupled system uses a single dual function inverter. This inverter is tied to both the PV array and ESS, and it communicates with the ESS charge controller to make dispatching decisions for the system. The following figure illustrates a possible DC Coupled System configuration (Figure 2).



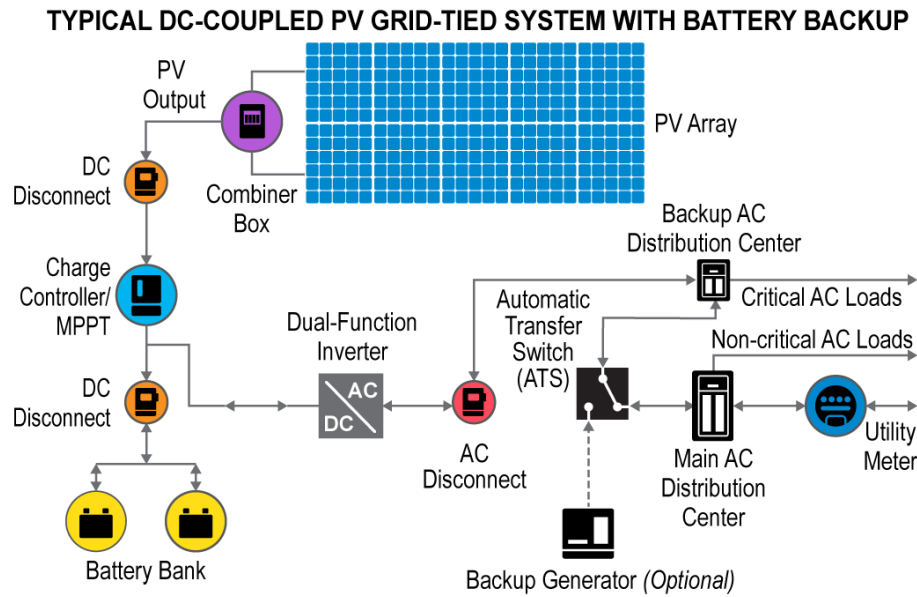

Figure 2: DC-Coupled Resilient PV

Advantages: The efficiency of the system is slightly higher due to fewer conversions between AC and DC. There are fewer inverters, resulting in less points of potential failure. The cost of inverter replacement is less due to fewer inverters. All dispatching decisions are made in a single location resulting in less complicated controls.

Disadvantages: As a retrofit, there is more electrical reconfiguration that must be completed. DC coupling is often times more costly to implement as a retrofit due to re-design costs, removal of existing equipment, and re-wiring. A new interconnection agreement will need to be filed with the serving utility.

AC Coupled Systems

An AC Coupled system uses a grid tied inverter for the PV array, as well as a dual function inverter to charge and make dispatching decisions for the system. The dual function inverter monitors the state of charge of the batteries, the electricity going to load, and the energy being produced by the PV array. The following figure illustrates a possible AC Coupled configuration (Figure 3).



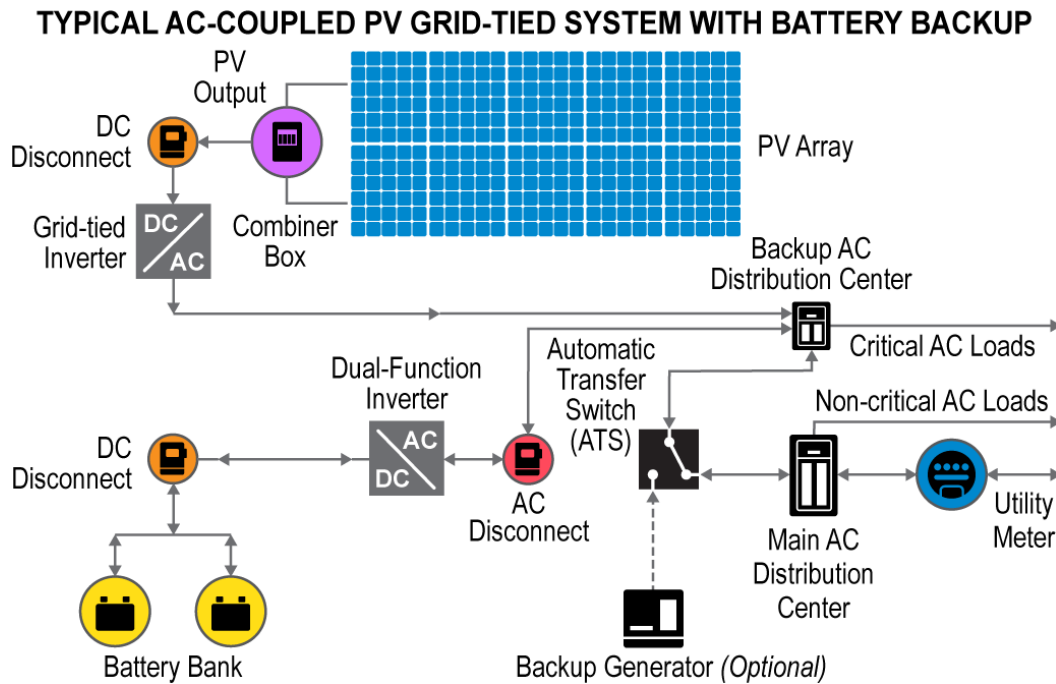

Figure 3: AC-Coupled Resilient PV

Advantages: For a facility with an existing PV systems, AC-coupling enables the use of the existing inverter. This configuration may be preferable for some third-party owned systems, where a DC-coupled retrofit would require removal of existing equipment and violate terms of the ownership agreement.

Disadvantages: The grid-tied inverters must be able to communicate with the dual-function inverter to control the PV production of the system and match the loads in the system. The configuration involves more conversions from AC to DC and back, resulting in conversion losses as much as 10% higher than DC coupled systems when charging the batteries⁶. A new interconnection agreement will need to be filed with the serving utility unless the new inverter and batteries will only be used for emergency power and will never operate in parallel with the grid.

Site characteristics are typically the largest driver when it comes to making a decision between AC and DC coupled systems. Based on the site characteristics, the lowest cost option and the most streamlined integration are typically the drivers of design decisions.

Equipment Compatibility

Compatibility between PV and battery systems should be assessed by a project developer or by contacting equipment manufacturers before retrofitting an existing PV system with storage since some equipment is not capable of communicating with equipment from another manufacturer.

Communication between inverters is moving towards a Modbus platform away from the currently used serial RS485 system.

Standard protocols that will allow for more “plug and play” across resilient PV equipment are currently in development. The SunSpec Alliance, a trade alliance, is leading these efforts. Once voluntary SunSpec

⁶ Based on typical weighted average inverter efficiency from the California Energy Commission Database. http://www.gosolarcalifornia.ca.gov/equipment/inverter_tests/summaries/



guidelines are adopted, consumers will be able to more easily identify compatible equipment. However, legacy equipment will still face communication challenges.

Practical Considerations

Creating a stable off grid system can be challenging due to individual site loads, inrush current spikes, nuisance trips, and staging the system from black start. Packaged systems that come pre-engineered are often more simple to implement and require less time on integration than a system built up from the component level.

Depending on the battery type, inverters can sometimes manage the batteries based on voltage and current measurements. Lithium ion batteries require more sophisticated controls, and typically require a battery management system (BMS) external to the inverter. Typically, the BMS takes internal status measurements within the battery before energizing the main DC bus. For the system to be able to black start, an external power supply is required to energize the BMS prior to power being provided at the DC output of the battery. The power supply is typically a 24 volt DC battery. An external “pre-charge box” is often implemented as a secondary protection to ensure battery systems are not damaged as a result of unwanted current and voltage spikes at startup.

Selecting a knowledgeable commissioning agent/contractor that demonstrates and tests all modes of operation is key to the successful implementation of the system.

Equipment List

There are a number of ways in which a PV system can be made resilient, and a multitude of different ways these systems can be implemented. This section will cover the most common configurations with a list of equipment that needs to be added or planned in each retrofit scenario. The components in the following table will be included in nearly all systems.

Equipment needed to add an ESS to a residential or small scale commercial solar PV system:

- Batteries
- Dual function inverter
- Critical Load Panel
- Isolating Switches
- Controls
- Metering
- Balance of System Items (racking, wire, etc.)
- Transfer Switch (automatic or manual)

*In order to implement a **DC coupled** system:*

- Remove the existing grid tied inverter
- Add a dual function inverter
- Add a transfer switch (if not included in the inverter)
- Add a charge controller
- Add a battery bank
- Add a DC disconnect
- Configure controls hardware/software
- Isolate critical loads
- Add surge protectors (optional)

*In order to implement an **AC coupled** system:*

- Add a dual function inverter to the system
- Add a transfer switch (if not included in the inverter)
- Connect the existing grid tied inverter to the dual function inverter
- Add a battery bank
- Add a DC disconnect
- Configure controls hardware/software
- Isolate critical loads
- Add surge protectors (optional)

A complex commercial scale system may require additional equipment such as:



- Advanced controls for quick or seamless transfer from grid mode to back-up mode
- Fire suppression systems
- Electrical protections

Sizing for Storage

The size of the inverters and batteries added to a solar system will depend on its uses. If the ESS will only be used for back-up power on a single family home, the ESS will be sized to support critical loads only. If the ESS will be used for both back-up power and demand management (i.e. peak shaving and/or demand response), the size of the ESS will depend on the size and duration of the building’s peak load as well as critical power needs. There are sophisticated calculation tools⁷ that can be used to optimize system sizing using measured loads and projected PV production.

Sizing equipment for a resilient storage system involves weighing the design alternatives, and finding where capital cost, functionality, and value all align. In an optimal system, the facility will receive sufficient emergency power and electricity bill savings while keeping capital costs reasonable.

Typical Solar and Storage System Sizes Across Sectors			
	Residential	Commercial	Utility
Solar	≤ 25 kW	25 kW-1 MW	≥ 1 MW
Battery	< 10 kWh (KW)	10 kWh (kW)–1MWh (MW)	> 1 MWh (MW)

Critical Loads for Emergency Power

Critical loads are site-specific and typically selected by the customer identifying which electrical equipment is essential in the event of an outage. Financial and physical space constraints can also inform system sizing.

Example critical loads include:

- Refrigerators
- Lighting
- Elevators
- Life safety equipment
- Booster pumps
- Sump pumps
- Computers
- Select plug loads
-

Examples of equipment that may be excluded from the critical load are:

- HVAC equipment and electric heaters*
- Exterior lighting
- Dishwashers
- Electric water heating
- Irrigation pumps
- Other non-essential loads

*This may be considered critical for populations, such as seniors, with heightened temperature sensitivity.

⁷ Examples of modeling software include: [NREL System Advisor Model](#), [HOMER](#), and [RETScreen](#).



Calculating Critical Loads

The energy required for critical loads is measured in units of kW (power) and kWh (energy). It can be measured at the distribution panel, or calculated using information from the nameplates of the critical equipment. Once the critical load is known, the battery inverter is sized (in kW) to meet this peak demand, taking into account ramp up requirements and load spikes. The batteries are sized (in kWh) by the duration of the discharge required, i.e. how long the critical load must operate. Typically, if there is a desired run time, the battery is sized for the worst case scenario where there is full load and no PV generation.

$$Rated\ Battery\ Capacity\ (kWh) = Critical\ Load\ (kW) \times Run\ Time\ (hrs)$$

Alternatively the number of hours of critical load run time can be calculated by comparing the rated battery capacity to the critical load.

$$Run\ Time\ (hrs) = \frac{Rated\ Battery\ Capacity\ (kWh)}{Critical\ Load\ (kW)}$$

The actual available run time will depend on the state of charge of the battery at the time of loss of grid power. These equations provide a simplified estimation of battery capacity and run time. Detailed design should account for transient spikes, a safety factor for unanticipated loads, and other factors. A professional should be consulted for more complex and accurate calculations.

Site Considerations

Siting considerations should be examined at the outset of a project, as system siting can determine if the project is feasible or not. In general, the best siting locations must be conditioned to meet ESS space constraints, operating temperatures and humidity limits. It is also favorable to have a clean space to avoid rapid deterioration of electronics.

Space Considerations for Residential & Small Scale Commercial Systems

- **Inverter:** AC-coupled systems will require additional space for the second inverter. Large commercial systems may require multiple inverters.
- **Batteries:** Both residential and commercial systems require a floor space footprint, and clearance as specified in the National Electric Code. Batteries are typically modular and often times can be configured to fit within site constraints. Batteries vary in power density, so the space required will vary depending on the battery chemistry used⁸ in addition to the storage capacity required for the application. Residential systems may require about as much space as a small refrigerator. Commercial systems range in size greatly, and may require one or several large cabinets of batteries. A typical footprint of a li-ion battery cabinet is on the order of 4 square feet of floor space, but may increase in size if additional equipment such as a venting system is included.
- **Electrical Equipment:** Switches, distribution panels, critical load panels, meters and other electrical equipment will require wall space to be mounted. These components are typically located adjacent to existing service panels and may be either indoor or outdoor⁹.

Location Considerations for Residential & Small Scale Commercial Systems

- If possible, new equipment should be sited near the point of common coupling with the utility and/or existing equipment to minimize conduit runs.

⁸ See the “Battery Comparison Table” in the DG Hub’s [Resilient PV Hardware Fact Sheet](#) for more information.

⁹ The National Electric Code (NEC) specifies clearances, maximum distances, and permissible locations for electrical equipment. New York State has a minimum code requirement to comply with NEC 2008. Municipalities may have requirements above the state minimum requirement.



- Some battery chemistries may require temperature control, which may influence if the system is better sited indoors or outdoors.

Regulatory Considerations for Residential & Small Scale Commercial Systems

- Inverters should comply with [IEEE 1547](#) and [UL 1741](#)
- New equipment in NYC may not be installed below the flood plain.
- Siting batteries outdoors in NYC is often easier than indoor siting due to DOB and FDNY requirements.
- See the DG Hub [ESS Permitting and Interconnection Guide for NYC](#) for more code guidance.

Financing Considerations

Third-party Financed

Individuals with existing solar systems that are financed through a third party like a lease or power purchase agreement (PPA) need to determine if adding ESS to their solar system violates the terms of their financing agreement. It is unlikely that a DC-coupled system, which would require replacement of an existing inverter, could be added without violating a lease or PPA. However, a customer could request to restructure the terms of the lease or PPA to accommodate a DC-coupled system. An AC coupled system may be allowed. Customers should contact their installer or financing provider¹⁰.

Direct Ownership

Individuals who own their solar system outright may add energy ESS in whatever configuration they prefer, subject to potential review of the interconnection agreement with the utility (discussed in the *Interconnection & Net Metering* section).

The table below summarizes likely system configuration for an ESS retrofit by the ownership type:

<i>Ownership Type</i>	<i>Likely Retrofit Configuration</i>	<i>Considerations</i>
PPA	AC coupled	System Interactions, Contract Language
Lease	AC coupled	Contract Language, Meter Location
Energy Savings Performance Contract	AC coupled	ESCO Guarantee Impact
Direct Ownership	AC or DC coupled	Compatibility with Equipment Warranty

Investment Tax Credit

There is currently no tax incentive directly in place for ESS; storage must be paired with a renewable energy system to take advantage of the [Investment Tax Credit](#) (ITC). ESS that are integrated with solar have been able to monetize the 30% federal investment tax credit (ITC) for the cost of the solar and batteries when at least 75% of the energy used to charge the battery comes from the solar system.¹¹ The amount of tax benefit that can be claimed on the ESS scales with the percent of solar energy that is used to charge the battery. It may be possible for a *retrofit* system to claim the tax credit for the ESS if the ESS is deemed to

¹⁰ In conversations with solar developers, resiliency retrofits are not common enough to develop standard guidance on the process currently.

¹¹ Internal Revenue Service. (February 2013). Private Letter Ruling 121432-12. Retrieved from: <http://www.irs.gov/pub/irs-wd/1308005.pdf>



be “integral to the operation of the [solar] system.”¹² The IRS has expressed these rules in private letter rulings. Further guidance from the IRS is expected in the future following an IRS request in October 2015 for comments to clarify qualifying property for the ITC, including energy storage.¹³ Consulting with a tax professional is recommended for facilities interested in the ITC.

Warranty

To ensure the addition of an ESS will not void warranties on the existing PV equipment, such as inverters, warranties for existing equipment should be reviewed carefully. All information related to what is acceptable under the equipment warranty can be found in a “Warranty Conditions” document, an “Operational Manual”, and in an “Installation Manual”. These documents come with the projects, and can also be found on the manufacturer website. As with third-party financed systems, an AC-coupled system is less likely to void equipment warranties.

Interconnection & Net Metering

Interconnection

An ESS that is grid-interactive and will operate in parallel to the grid will require an interconnection agreement. For grid interactive AC Coupled retrofit systems, two interconnection agreements will need to be signed with the utility. One interconnection application will be submitted for the solar, and another application will be submitted for the ESS. In each application, the holistic system design should be presented, to allow for utility engineers to determine the appropriate rate classes for each of the agreements.

For grid interactive DC Coupled retrofit systems, a single interconnection agreement will need to be signed with the utility. The capacity of the dual function inverter will be put in the application. The electrical diagrams should also include the holistic system design and describe the system operation in all modes of operation. See the Con Edison section of the DG Hub [ESS Permitting and Interconnection Process Guide](#) for guidance on projects in NYC, and the New York State [Standard Interconnection Requirements](#) for comprehensive requirements and instructions. Note: Applications for systems under 50 kW do not include an application fee.

An interconnection agreement for an ESS may not be required if the ESS is not interconnected to the grid. A system that will not operate in parallel to the utility grid will not require an interconnection agreement. For example, an ESS that is only used for back-up power and not interconnected to the grid would not require an interconnection agreement.¹⁴ Solar systems, unless always fully off-grid, will still require interconnection agreements.

Net Metering

System control strategy may impact a customer’s ability to net meter. Customers should consult with their utilities before adding an ESS to their solar system.

¹² Clean Energy Group. (February 2016). Financing Solar+Storage with Federal Tax Credits. Retrieved from: <http://www.cleangroup.org/wp-content/uploads/Webinar-Slides-2.3.2016.pdf>

¹³ https://www.irs.gov/irb/2015-43_IRB/ar01.html

¹⁴ Some utilities request any emergency source of generation to sign an affidavit that states their technology will never interconnect with the grid unless instructed to do so by the ISO or their utility due to an emergency.



Currently, for utility customers in NYS, net metering solar with an ESS is permissible under the following scenarios:

1. If solar and ESS are not electrically connected, and are connected behind two separate meters, then the solar system may net meter. Note that the ESS may not net meter in this scenario.
2. If the solar and ESS system are connected behind one meter, and if the ESS is configured to shut off or ramp down if/when solar energy begins to export onto the grid, then the solar system may be net metered. This configuration requires additional review time and/or inspections by utility engineers to ensure proper relay settings.
3. If the solar and ESS system uses one meter and is configured such that the ESS is only charged from the solar array (i.e. ESS is unable to charge from the grid), then the system may net meter.
4. If the solar and ESS system uses one meter and is configured such that the ESS is only used during grid outages (for example, via an automatic transfer switch), then the system may net meter.

Note: A [joint proposal](#) between utilities and solar companies was filed with the New York Public Service Commission in April 2016, aiming to move New York away from current net metering policies. Changes to net metering policies are likely under the state's [Reforming the Energy Vision](#) process.

To qualify for net metering, an interconnection application that includes an ESS generally requires a technical review to ensure that the system meets the conditions outlined above. A clear narrative with diagrams showing export controls for the system may expedite the review by utility engineers in determining if the system qualifies for net metering.

Some customers find different rate structures more advantageous when they add solar and storage to their home or facility. See the *Tariff Guidance for Solar and ESS Customers* section in the DG Hub [ESS Permitting and Interconnection Guide for NYC](#).

Costs

There is a large cost range for retrofitting solar with storage. Costs will vary based on system size, battery chemistry, quality of equipment, site constraints, local labor costs, etc. The industry is also in a period of rapid cost reduction, where year over year hardware and soft costs drop by as much as 14% per year¹⁵.

Based on preliminary estimates from a forthcoming NREL study, the estimated cost to add storage to a residential PV system as a retrofit is expected to be on the order of \$2,000-\$3,000/kWh as a function of system energy content or \$4,000-\$6,000/kW as a function of system power capacity. This equates to \$20,000-\$30,000 for a 10 kWh storage system. The estimated cost to add storage to a commercial PV system as a retrofit are estimated to be on the order of \$800-\$1500/kWh as a function of system energy content or \$1,600-\$3,000/kW as a function of system power capacity. This equates to \$40,000-\$75,000 for a 50 kWh storage system.

Batteries and inverters typically last between 10 – 15 years before replacement is required. Equipment lifetime will depend on how the system is used (frequency and depth of discharge). Most li-ion batteries and inverters come with a 10-year warranty. In developed energy storage markets, commercial systems will typically provide value to the site that provides a return on investment. Depending on what function the ESS serves, paybacks can range from 5 years to 20 years. The most lucrative value stream for commercial systems tends to be peak shaving. In areas where the ESS value does not provide a return on investment

¹⁵ Clean Technica. (March 2015). EV Battery Costs Already ‘Probably’ Cheaper than 2020 Projections. Retrieved from: <http://cleantechnica.com/2015/03/26/ev-battery-costs-already-probably-cheaper-than-2020-projections/>



in less than 20 years the system should only be implemented if there are other services that the system provides that cannot be monetized, but are valuable to the facility (backup power, power quality, etc.). See the DG Hub [Economics and Finance of Solar+Storage](#) fact sheet for more information.

Storage Ready Considerations

Converting traditional PV to resilient PV is easier and less costly when the initial PV system is designed to be retrofitted with storage. Making a PV system “storage ready” requires more thought, planning and upfront costs, but should lead to an easier and more affordable retrofit when storage is added in the future. Many of the considerations for retrofit systems will apply to storage ready systems as well, but the following sections provide additional considerations for storage ready projects.

Design Considerations

PV systems can be made storage ready as either DC or AC coupled configurations. To make a PV system storage ready for DC coupling, a dual function inverter can be implemented in place of a grid tied inverter when the PV is installed. A dual function inverter will increase the initial cash outlay (~40% cost premium on inverter cost)¹⁶. When the customer is ready to add an ESS, it can be integrated into the dual function inverter without additional system re-configuration. Most inverters are warranted for 10 years, so a DC coupled system would make sense for a customer who plans to add an ESS within a few years of installing a PV system. Additionally, DC coupled systems designed to be storage ready can connect the ESS without an additional interconnection agreement (only utility notification is needed). The schematic below shows the components that would be implemented (Figure 4).

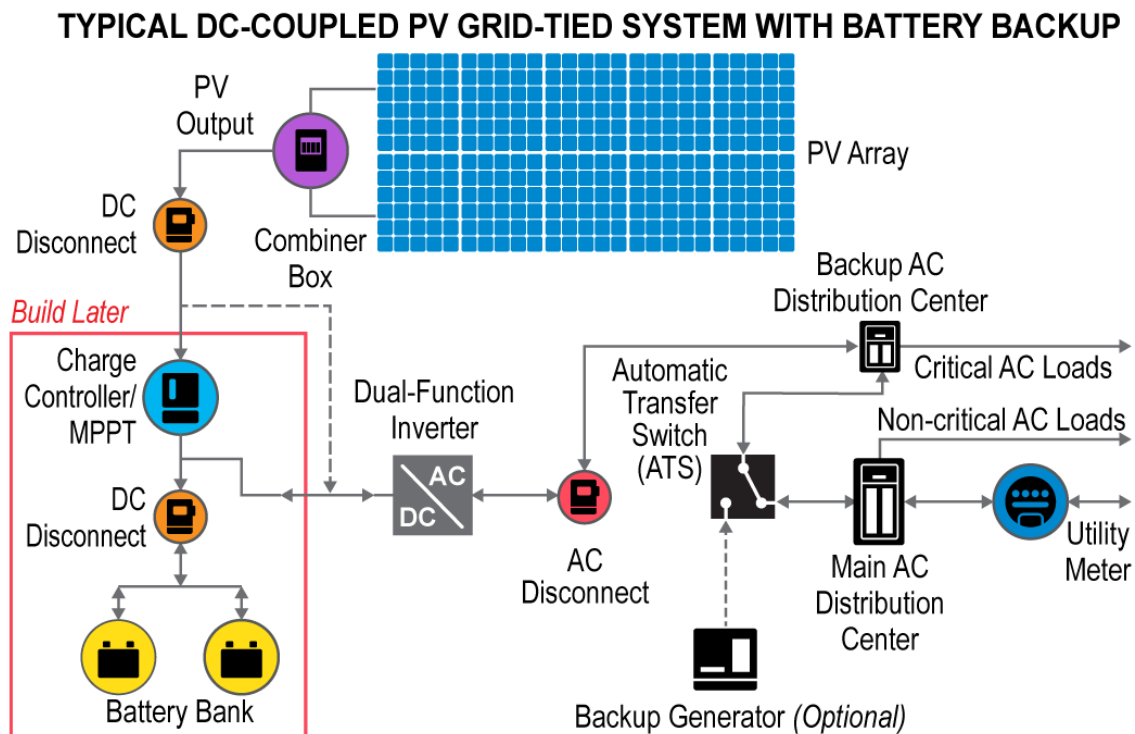

Figure 4: DC-Coupled Storage Ready Schematic

¹⁶ Communication with solar and storage project developer 5/12/2016

To make an AC-coupled system storage ready, a grid tied inverter can be implemented, and the electrical work can be performed to allow for the quick connection of a dual function inverter when the customer is ready to add an ESS. Conduit can be laid, and wire can be run to the places where the equipment will be installed. The schematic below shows the components that would be implemented (Figure 5).

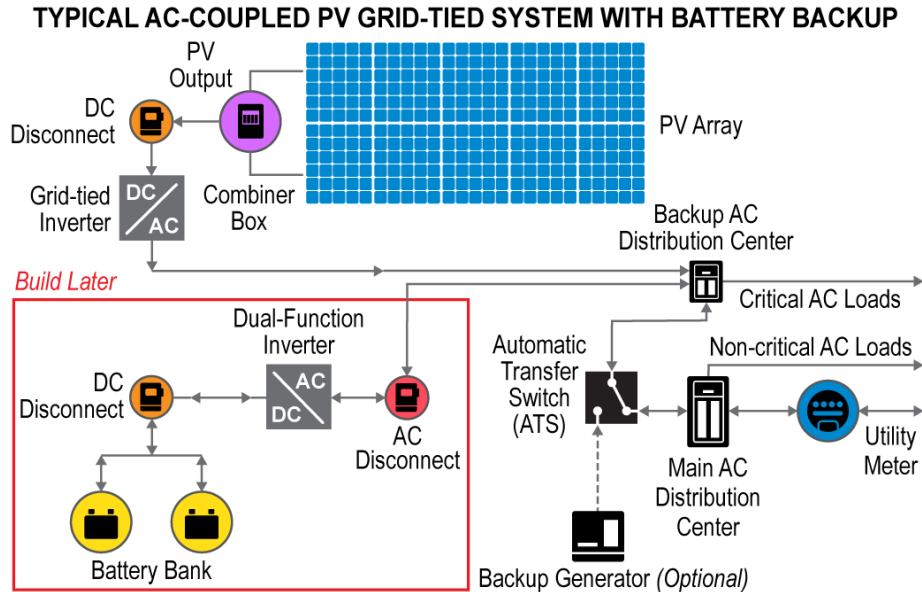

Figure 5: AC- Coupled Storage Ready Schematic

Regardless of system configuration, storage ready systems designed to provide emergency power should identify critical loads and install a critical load panel when the PV system is installed. The systems should also have a transfer switch installed (if the inverter does not have an integrated transfer switch) that will switch from grid mode to emergency mode and energize the critical loads. Some of the considerations for making a PV system storage ready are no cost modifications. They include: allowing space in the mechanical rooms for equipment, adjusting layout of equipment to accommodate electrical modifications for future equipment, and thinking through how the system will be implemented.

Equipment List

When adding an ESS to a system that was designed to be storage ready with a DC coupled configuration, the following equipment is needed:

- Batteries
- Isolating Switches
- Controls
- Metering
- Balance of System Items

Site Considerations

Solar equipment should be sited with future ESS equipment in mind. When possible, identify and leave space for the batteries and possibly a second inverter (if AC coupling will be used) where it can easily tie into existing equipment and the electrical system. Designated space should be located above the flood plain to avoid permitting complications.



Financing Considerations and Warranty

If third party ownership of the PV or ESS is desired, check with the provider in advance to see if an ESS may be added after signing the initial agreement. Similarly, review solar equipment warranties before implementing the system with the addition of an ESS in mind. Look for language that would indicate warranty being voided by off-grid operation.

Investment Tax Credit

It may be possible for a retrofit system to claim the tax credit for the ESS if the ESS is deemed to be “integral to the operation of the [solar] system.”¹⁷ The IRS has expressed these rules in private letter rulings.

Interconnection and Net Metering

Some utilities may allow customers to file an interconnection agreement for the end state of the resilient PV, of which only the solar components are initially constructed. In this case, the original interconnection agreement would need to be amended when the energy storage is implemented. If a second inverter is added, or the existing inverter is replaced by a different model, a separate interconnections agreement is required once the system is implemented. Other utilities will always require a separate interconnection agreement to be filed when the energy storage is added. At this time, retrofitting solar with storage is still relatively uncommon, and processes are being defined. Clear communication with the customer’s utility regarding future intentions to add energy storage is advised at the outset of the project to determine interconnection requirements for adding energy storage to a system in the future.

Costs

The cost savings associated with making a system storage ready vary greatly based on system size and the difficulty in which the preparations are made. The largest savings from storage ready system is the result of labor savings for completing the retrofit. If the systems is implemented in such a way as to minimize construction and electrical labor, the savings can be substantial. The next largest cost saving is ensuring that the inverter from the solar array can be used with the combined system. Based on preliminary estimates from a forthcoming NREL study, initially constructing a solar system to be storage ready could increase the system cost by 12% - 17%. In a residential system, that equates to \$2,000 - \$3,000. The cost savings that can be realized once the ESS is implemented could reduce the cost by 18% - 27%. In a residential system, that equates to \$3,000 - \$4,500, resulting in break-even costs or savings up to \$2,500. Additional savings could be realized in the interconnection and permitting process if the end state system is included in the initial application submittal, but this value is highly location and jurisdiction dependent.

Please note: Information included herein does not constitute legal advice. Parties should consult with the appropriate professionals before proceeding.

¹⁷ Clean Energy Group. (February 2016). Financing Solar+Storage with Federal Tax Credits. Retrieved from: <http://www.cleanegroup.org/wp-content/uploads/Webinar-Slides-2.3.2016.pdf>



CASE STUDY: STORAGE READY PV SYSTEM

A home in upstate New York experiences relatively short grid outages each year, but the homeowners are concerned that the outages may become problematic if they start working from home more often. They already decided to implement solar to reduce utility bills, and wanted to make sure that resiliency could be added quickly without completely re-building the system. A 15 kW PV system is implemented with 3 grid-connected inverters to supply the electricity needed for the home. The system is built in three separate arrays, each with 5 kW and an independent inverter. The critical loads of the home are separated from the main distribution panel on a subpanel. An automatic transfer switch isolates the system from the grid in an outage. The homeowner determined that all loads (plug-ins, lighting, refrigeration, cooking, ventilation fans, and security system) except for air conditioning are to be included in the critical loads. The solar panels, the grid-connected inverters, the critical load panel, and the automatic transfer switches are implemented as part of the first phase of the system. This allows the homeowner to save money on utility bills by net metering the PV system. The first phase of the system will not provide power in a grid outage. The dual function inverters, the battery bank and the charge controllers were not implemented in the first phase of the project. These components will be purchased and added to the system when the homeowners decide that the resilience components become necessary as a second phase of construction. After the second phase of the project, the system will produce solar energy, the system will be net metered with the utility, and the system will provide power in the event of a grid outage. The system will need to re-apply for interconnection after the second phase is completed, as the system will be AC-Coupled with two sets of inverters.

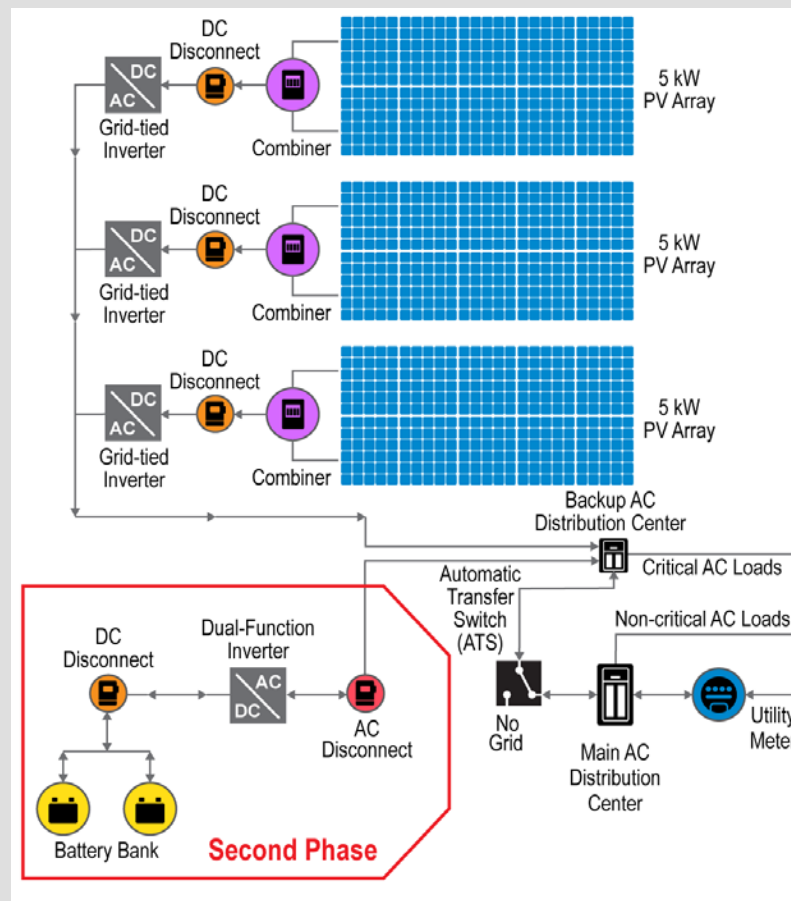



Roof Mounted Solar Array – Image Credit NREL Image Gallery #18067



Electrical Equipment – Image Credit NREL Image Gallery #13326

Contributing Organizations

SMA America
 Bright Power Inc.
 Cairn Energy Research Advisors
 Outback Power Systems
 National Renewable Energy Laboratory
 Princeton Power Systems
 SunSpec Alliance
 New York State Net Metering and Interconnection Working Group
 DG Hub Hardware Technologies Working Group: NYSERDA, NYPA, Genesys Engineering,
 Clean Energy Group, NY-BEST, FDNY, HOMER Energy

ABOUT

CUNY is the lead implementer of the NYSolar Smart DG Hub, in partnership with Meister Consultants Group and the National Renewable Energy Laboratory. The DG Hub is supported by the U.S. Department of Energy’s Solar Market Pathways program, the NY-Sun Initiative, and the New York Power Authority. The DG Hub thanks the Hardware Working Group for their support in the development of this resource.

The information, data, or work presented herein was funded in part by the Office of Energy Efficiency and Renewable Energy (EERE), U.S. Department of Energy, under Award Number DE-EE0006913. The views and opinions of authors expressed herein do not necessarily state or reflect those of the United States Government or any agency thereof.

CONTACT: DGHub@cuny.edu, www.cuny.edu/DGHub



Attachment A

General How-to Guidelines and Work Specification Language

This section includes example language from RFPs for procuring an ESS that is integrated with solar.

WORK SPECIFICATION

The contractor is required to design, construct and effectively demonstrate a resilient PV system that is capable of powering the essential loads in back up or emergency mode with utility service compromised or unavailable. The resilient PV system shall provide the ability as needed or desired to black start during utility disturbances/interruptions or system testing. The system will integrate existing renewable energy and energy storage systems, and generation systems. Use of generators should be reduced in favor of the renewable energy technologies, where feasible. The resilient PV system shall be controlled by a central control system that will balance generation and load to provide power to the critical loads during a grid outage. The system shall also be used in grid-connected mode to further optimize installation energy use and provide cost savings where feasible. This project shall be designed to be scalable and systematically expandable to include new loads, generation sources, and SunSpec compliant control systems.

<Insert site characteristics with images, available space, electrical connection location, etc.>

The contractor shall be responsible for all necessary analyses, forms, applications, and fees required for the customer to obtain an interconnection agreement (IA), permits, and incentives, for the project.

The resilient PV system shall utilize and integrate with the customer's solar PV, and energy storage systems in both backup and grid-connected modes. The resilient PV system shall be capable of functioning with or without these distributed resources. Inverter firmware upgrades and new communications will likely be required. The customer shall be able to adjust reactive power, voltage and frequency ride-through capabilities, and inverter power output to set levels with controllable ramp rates.

The details of the existing system are listed in an attachment.

<Add attachment with existing equipment>

<Note if any of the existing systems are owned or financed by entities other than the customer>

Provide advanced functionality upgrades to the existing PV systems such that the end state system can monitor energy/power production, loads, and control the ESS. This is to be accomplished in an automated fashion by the system controls such that system stability will be maintained in backup mode.

A transfer switch will automatically (or manually) electrically isolate (sectionalize) the critical loads of the customer facility that require power from the non-critical portions of the facility. This may require electrical re-configuration and the installation of a critical load distribution panel. Provide necessary switchgear and protection equipment consistent with NEC and typical safety practices.

Prior to final close out, the contractor must demonstrate all functionality of the system, and educate the customer on operation, manual overrides, maintenance, and support resources. Demonstration shall include operation of the system in grid connected, backup, and test modes. The following functional tests will be performed:

- Rated voltage and current
- Validate power supply
- Validate protection circuits (including output current limit level)



- Validate cooling system functionality and temperature rise
- Validate DC bus pre-charge
- Validate insulation resistance
- Measure noise generation
- Voltage harmonic content under no-load and loaded conditions
- Ramping capability for active and reactive power
- Frequency responsive controls
- Transition from grid-connected (current source) to grid-forming (voltage source) modes and back

SUBMITTALS

- ESS manufacturer’s catalog data, MSDS, cut sheets, performance data and detailed shop drawings.
- Inverter manufacturer’s catalog cut sheets, performance data and detailed drawings.
- Disconnect switch manufacturer’s catalog cut sheets and detailed drawings.
- Complete as-built three-line wiring diagrams for the ESS.
- Drawings shall include the functional relationship of various equipment

WARRANTY AND MAINTENANCE

Provide a complete warranty of all components including replacement labor extending 5 years after date of system start-up and acceptance / commissioning. Provide an option for a yearly maintenance contract for the ESS after the 5-year warranty period. The Warranty Service and the proposal for a Yearly Service Contract shall be based upon the manufacturer’s standards.

OPTIONAL

The system controls will have the capability of generator starting and stopping, PV system output regulation, and ESS charging/dispatching.

Provide a resilient PV system capable of executing economic dispatch opportunities including but not limited to demand response, peak shaving, ancillary services, peak load management, reactive power and voltage support, retail energy time shift, renewable variability smoothing, and self-generation:

- Provide the ability for the resilient PV system to accept and integrate an automatic demand response signal from the serving utility (compliance with openADR 2.0B shall be required). The resilient PV system shall be capable of accepting this signal, sending acknowledgement of receipt to the utility and automatically dispatching ESS.
- Expect the response time to be as quick as 30-60 seconds for certain utility response services.

The contractor shall be responsible to retrofit the switches to allow automatic open/close function, controlled by the resilient PV system controller directly or indirectly through the SCADA system.



QUALIFICATIONS

Provide references for similar projects that have been completed successfully that demonstrate all of the functionality that has been specified herein. Systems shall be fully commissioned and demonstrate all modes of operation in a synthesized test. Preference will be given to organizations that can show experience in local markets with 5 or more years of experience.

Additional Resources

Additional RFP resources are available on the DOE Office of Energy Efficiency and Renewable Energy website.

<http://apps3.eere.energy.gov/greenpower/financial/archives.shtml>

Additional RFP resources are available on the National Renewable Energy Laboratory website.

<https://financere.nrel.gov/finance/content/renewable-energy-contracts-library>

Additional RFP resources are available on the Clean Energy Group website.

<http://www.cleanegroup.org/ceg-resources/resource/energy-storage-procurement-guidance-documents-municipalities/>

